THE GIANT-VAC
Self-Contained Truck
Loader
MODEL TLR2910202BVG &
TLBR3510252BVG

OPERATOR'S MANUAL

Congratulations!

You have just purchased one of the finest pieces of outdoor power equipment on the market today. If properly cared for, your Giant-Vac Model TLR2910202BVG/TLBR3510252BVG Self-Contained Truck Loader will provide years of dependable service. Please read and follow this instruction manual carefully in order to get the most out of your new equipment.

First, inspect your machine upon delivery. Each Giant-Vac product leaves our factory in excellent condition; occasionally, however, some damage may occur during shipment. If any such damage is found upon initial inspection, *immediately* notify the transport carrier who delivered your machine, as they are solely responsible for the damage as well as any subsequent adjustments.

Your Giant-Vac Model TLR2910202BVG/TLBR3510252BVG Self-Contained Truck Loader comes completely assembled. Simply follow the instructions contained within this manual to begin enjoying the benefits of your new unit.

CALIFORNIA PROPOSITION 65 WARNING

Gasoline and Diesel engine exhaust and some of its constituents are known to the State of California to cause cancer, birth defects and other reproductive harm.

As an owner of off-road gasoline or diesel engine equipment and/or as an employer, you also may have an obligation under the California Occupational Safety and Health Act or under Proposition 65 to warn persons exposed to gas and diesel engine exhaust and/or other Proposition 65 chemicals in and around your workplace. See California Health and Safety Code section 25249.5, Title 22 of the California Code of Regulations at Section 1200 *et seq.*, and Title 8 of the California Code of Regulations Section 5194.

1

SAFETY RULES REGARDING OUTDOOR POWER EQUIPMENT

IMPORTANT! READ THE FOLLOWING SAFETY RULES *CAREFULLY* **BEFORE OPERATING UNIT:**

- Regard your Giant-Vac Model TLR2910202BVG/TLBR3510252BVG Self-Contained Truck Loader as a piece of power equipment and teach this regard to all who will operate this unit. Never allow children or young teenagers to operate the unit.
- Always wear appropriate safety equipment when operating this unit. Proper eye, ear, and breathing protection is a must.
- Be sure you know how to stop both the unit and the engine at a **MOMENT'S NOTICE**. Refer to the operation section of this manual, as well as the engine manual.
- Do not operate with any guards or component parts removed from unit.
- Unless there is very good artificial light, use only during daylight.
- Fill gasoline driven machines outdoors. Avoid spilling gasoline and **DO NOT** fill the engine while it is running or while you are smoking.
- While in operation, keep all parts of body away from intake and exhaust sections. Never insert any body part or other foreign object in any opening while the machine is running.
- Never operate the unit with the back door open or unlocked.
- When operating unit, keep people and pets a safe distance away. Instruct children to keep away from the area of operation at all times.
- Do not use on steep inclines (over 30 degrees), as unit can roll over.
- Before making any adjustments or repairs, stop engine and remove spark plug wire.
- Never allow another person to ride, sit or stand on the Giant-Vac Truck Loader.

FAILURE TO FOLLOW THESE RULES CAN RESULT IN CHRONIC HEALTH PROBLEMS, SERIOUS INJURY, OR EVEN DEATH.

2

UNIT OPERATION

1. ASSEMBLY:

The boom holders are located on the side of the exhaust stack and elbow (ref #34). Next the boom should be installed in the holders by sliding the vertical arm into the upper bracket on the exhaust stack and elbow and then dropping down into the lower bracket. The outrigger arm is next installed and fastened with a ½" bolt and lock nuts. The threaded support spring arm is fastened which completes this assembly.

2. HOSE ASSEMBLY AND POSITIONING:

Install the hose next and secure to the flange by means of a stainless steel hose clamp. Then slip the boom hose support over the hose. This should be secured about two (2) feet from the end of the hose. The pickup nozzle is installed next and fastened with a second hose clamp.

A chain connects the hose support band to the end of the boom. It is vitally important that this chain is adjusted correctly for ease of operation. In general, the chain should be so adjusted that the nozzle is approximately 16 inches off the ground.

The ultimate check to be certain this adjustment is correct takes place after the machine is running at operating speed. To make this check, speed up the engine. You should then be able to push the nozzle to the ground and pull it back up by using three fingers of one hand. If you cannot operate the nozzle accordingly, either the chain should be readjusted or the spring tension of the boom assembly changed. Taking a few minutes to adjust this correctly will ensure ease in operation.

For transport, move the intake hose forward and lock the intake nozzle handle to the nozzle holder for transport.

Attach the spring holders to the rear door (facing out or to the back of the machine) with 3/8" bolt, nut and lockwasher. Next, connect the door spring and chain from the spring holder to the chain holder on the top of the machine. Repeat for the other side.

3. Engine:

NOTE: *If you experience problems with your engine that cannot be satisfactorily resolved by following the instructions contained within the engine manual, contact your local engine dealer, or call the toll-free service number listed in the repair section of the engine manual. All engine service, warranty or otherwise, is required to be performed by a manufacturer-authorized service center. Giant-Vac Mfg., Inc. is neither authorized nor responsible for any type of warranty engine service, nor is it equipped to perform any such service.*

BEFORE STARTING ENGINE:

- Be sure to read your engine manual carefully and thoroughly before attempting to start the engine.
- Be sure that the unit is **completely** assembled, and all safety guards and components are in place.
- Be sure to check engine's **oil** and **gasoline***. (See engine manual for recommended oil and gasoline specifications.) **Never** check the engine while it is running or while you are smoking. Check only when engine is cold.

*All machines are shipped without oil or gasoline unless otherwise noted.

- Be sure that red fuel valve on engine is set to open position.

TO START ENGINE :

- Set throttle control up to “full” position. If engine is cold, set choke by pulling out choke handle.
- Turn ignition key and hold until engine starts. (If engine fails to start within a reasonable amount of time, discontinue and check engine manual for further instructions.)
- After engine starts, release ignition key, move throttle control down to approximately half, and turn off choke as required.

TO SHUT ENGINE DOWN :

- Allow engine to idle for 2-3 minutes before shutting down.
- Turn ignition key to ‘off’ position.
- If engine is not to be started for a prolonged period, turn red fuel valve to closed position.

4. OPERATING THE UNIT:

1. **NOTE: ENGINE IS SHIPPED WITHOUT OIL** Follow the engine manufacturers recommendations for oil and fuel recommendations and service. This should be read carefully to ensure maximum engine life.

2. Be certain the intake hose boom is properly adjusted according to the instructions found in an earlier section of this manual. In operation, you will note the boom will readily swing over a 10-foot path. If the pile of leaves is high, a short back and forth flicking motion will effectively eat into the pile of leaves. If the leaves are wet, it is best to move into the pile with a “gulping” motion. In this way, you will pick up a quantity and then move the hose slightly away from the pile to allow the leaves to rapidly flush through.

3. In most cases, if the leaves are dry, we recommend running the truck loader at approximately half throttle. This will help reduce small particles of debris from escaping through the exhaust screen. When the leaves are wet or partially frozen, we recommend running the machine at full throttle.

4. **NEVER USE YOUR GIANT-VAC TRUCK LOADER TO PICK UP SAND OR STONES.** Debris like this is very abrasive and can damage the impeller and blower housing.
5. When the receiver box is full, stop the engine and move the intake hose nozzle forward and lock for transport. The machine is now ready to go to the dump.
6. Never run or operate your Giant-Vac Truck Loader unless it is completely connected to the receiver box and the intake hose is installed.

DUMPING THE LEAF BOX:

Your Giant-Vac Model 2510TR/3010TR Self-Contained Truck Loader has a 10 cubic yard* self-dumping leaf box. When the box is full, simply back the unit up to the desired dumping area **, loosen the two handle nuts on either side of the back door, swing the two pivot lock bolts out of the way, lift the spring-loaded back door, and the debris will slide out. If necessary, pull the unit forward a few feet to ensure complete emptying of the box. Be sure to close and lock the door before resuming operation.

* Approximate holding capacity

**** Before backing up, always make a visual assessment of the area behind the Trail-Vac, making sure there are no people (especially children) or objects behind the machine that could be backed into or run over. Failure to do so could result in serious injury, as well as severe machine and/or property damage.**

3

MAINTENANCE AND STORAGE

- Follow **implicitly** the engine manufacturer's recommendations for maintenance.
- Never make any adjustments to the Truck Loader until the engine is **off** and the spark plug wire is disconnected.
- If carburetor adjustment is necessary, stand to one side and **keep feet and hands** in the clear while making adjustments.
- Keep engine free of accumulations of grass, leaves or excessive grease. An accumulation of these combustible materials may result in a fire.
- Store gasoline in a **safe and approved** container in a cool dry place.
- Keep the Trail-Vac and fuel container in locked storage to prevent children from playing and/or tampering with them.
- Do not store gasoline powered equipment or fuel containers in a basement or any closed area where heating or heat appliances or open pilot lights are present, unless the fuel is completely drained from the power equipment and the fuel containers.

GIANT-VAC WARRANTY

GIANT-VAC, INC., here-in-after called Giant-Vac, warrants each new Giant-Vac to the original retail purchaser of the new Giant-Vac equipment to be free from manufacturing defects in normal service for a period of 1 year, unless it is used for rental purposes, which limits the warranty to 30 days. This warranty does not apply to engines, tires or other parts that are purchased and warranted by their manufacturer. Items such as bags, grass catchers, hoses and blades are not warranted, as these are considered expendable items. This warranty does not include equipment failures due to normal wear.

Any obligation under this warranty is expressly limited to the replacement or repair, at an authorized servicing Giant-Vac dealer, or at a point designated by us, of such parts as appear to us to have been defective. All defective parts have to be returned freight prepaid before credit will be issued.

We shall not be liable for transportation charges in connection with the replacement or repair of defective parts.

This warranty does not apply to a Giant-Vac upon which repairs or alterations have been made by others except with our prior written approval.

We shall not be liable for consequential damages or contingent liabilities for the fitness of any Giant-Vac for any particular purpose.

We make no other express, implied or statutory warranty, nor is anyone authorized to make any in our behalf.

Giant-Vac, Inc.
535 Macon Rd
McDonough, GA 30253

ENGINE, INTAKE AND DISCHARGE SECTIONS

<u>REF. NO.</u>	<u>PART NO.</u>	<u>DESCRIPTION</u>	<u>TLR2910202BVG</u>	<u>TLBR3510252BVG</u>
1	10229	Loader Base	1	--
1	10259	Loader Base	--	1
1a	31740	1/2-13 x 2 Hex Bolt (Mounts Base to Trailer Frame)	4	4
1b	31043	1/2 Flat Washer	8	8
1c	31489	5/8 Flat Washer	8	8
1d	31078	1/2 Lock Washer	4	4
1e	31406	1/2 Lock Nut	4	4
2	10035	Blower Housing	1	--
2	10220	Blower Housing (w/Bolt-in Wear Liner)	--	1
4	31033	3/8-16 x 1 Hex Nut	18	13
5	31008	3/8 Lock Washer	18	13
6	31009	3/8-16 Hex Nut	18	13
8	21517	Impeller	1	--
8	21518	Impeller	--	1
9,10	31447	5/8-18 x 2 Impeller Bolt & Key Group	1	--
9,10	31127	Impeller Key	--	1
9,10	31326	5/8 Lock Washer	--	1
9,10	31327	5/8 x 2 Impeller Bolt	--	1
11	20159	16" Intake Flange	--	1
12	31022	1/2 Hex Nut	--	12
13	31078	1/2 Lock Washer	--	12
16	40113	Fuel Tank	1	--
16	40140	Fuel Tank	--	1
17	31157	Fuel Tank Strap	2	--
--	31158	Fuel Tank Holder	1	--
--	30445	Inline Fuel Valve	1	--
19	40114	Fuel Cap - Specify Gas	1	1
22	61044	Valve Assembly	1	1
23	23165	Valve Handle	2	2
24	27199	Valve Handle Holder	2	2
25	31518	Wire Set	1	1
26	31519	Replacement Micro Switch for Valve Assembly	2	2
27	31195	1/4-20 x 1-1/4 Hex Bolt (Valve Assembly Mount)	3	3
27a	31013	1/4 Lock Washer	3	3
27b	31030	1/2-20 Hex Nut	3	3
28	61045	Hydraulic Hose 1/2 x 23 Valve to Jack	1	1
29	61046	Hydraulic Hose 1/2 x 43 Valve to Jack	1	1
30	61073	Hydraulic Fitting - 2501LL-8-8	1	1
31	61048	Hydraulic Hose 1/2 x 63 Valve to Hydraulic Power Unit	1	1
32	61077	Hydraulic Fitting - 2501-8-8	1	1
32a	61078	Hydraulic Fitting - 2404-8-8	1	1
33	61050	Hydraulic Hose 1/2 x 49 Valve to Hydraulic Power Unit	1	1
34	24634	Stack & Elbow Assembly (w/Wear Liner)	1	--
34	24635	Stack & Elbow Assembly (w/Wear Liner)	--	1
35	24636	Discharge Stack - Leaf Box Side	1	--
35	24637	Discharge Stack - Leaf Box Side	--	1
36	31532	Discharge Stack Gasket Set	1	1
37	31021	1/2 x 4-1/2 Hex Bolt	4	--
37	31086	1/2 x 1-3/4 Hex Bolt	--	12

ENGINE, INTAKE AND DISCHARGE SECTIONS (Cont.)

<u>REF. NO.</u>	<u>PART NO.</u>	<u>DESCRIPTION</u>	<u>TLR2910202BVG</u>	<u>TLBR3510252BVG</u>
38	31022	1/2 Hex Nut	4	12
39	31078	1/2 Lock Washer	4	12
40	31043	1/2 Flat Washer	8	24
41	31097	3/8-16 x 1-1/4 Hex Bolt	8	8
42	31009	3/8-16 Hex Nut	8	8
43	31034	3/8 Flat Washer	16	16
44	31008	3/8 Lock Washer	8	8
45	61017	Hydraulic Cylinder 24" (Hydraulic Jack Let)	1	1
46	27196	Cylinder Mounting Bracket	1	1
47	27197	Cylinder Clamp Bracket	1	1
48	31522	Cylinder Top Mounting Pin 1-1/4 x 7	1	1
48a	31835	1-1/4 ID x 3/4 Spacer	2	2
49	31523	1/2-13 x 1-1/4 Bolt/Lock Washer/Flat Washer Group	1	1
49a	31489	5/8 Flat Washer	1	1
50	31524	3/8 x Clevis Pin & Bridge Pin	1	1
51	61074	Hydraulic Fitting - 2501-6-8	1	1
52	31525	1/2-13 x 5-1/2 Hex Bolt (Clamp Bolt)	2	2
52a	31078	1/2 Lock Washer	2	2
53	31833	5/8-11 x 1-1/2 Hex Bolt	4	4
54	31834	5/8 Flat Washer (Modified 'D' Shape)	4	4
54a	31326	5/8 Lock Washer	4	4
55	31528	5/8-11 Hex Nut	4	4
56	31529	Jack Foot Pin 1-1/4 x 5	1	1
58	27198	Jack Foot	1	1
59	31523	1/2-13 x 1-1/4 Bolt/Lock Washer/Flat Washer Group	2	2
59a	31489	5/8 Flat Washer	2	2
60	33135	Safety Chain (Set of 2)	1	1
61	61079	Hydraulic Power Unit	1	1
61a	31492	3/8-16 x 3/4 Hex Bolt (Power Unit Mounting Bolt)	2	2
61b	31033	3/8-16 x 1 Hex Bolt (Power Unit Mounting Bolt)	2	2
61c	31034	3/8 Flat Washer	6	6
61d	31008	3/8 Lock Washer	4	4
61e	31009	3/8-16 Hex Nut	4	4
62	61080	Breather Cap	1	1
63	34019	Intake Hose 12" x 10'	1	--
63	34022	Intake Hose 16" x 7' Blue	--	1
64	34020	12" Hose Clamp	2	--
64	34024	16" Hose Clamp	--	1
65	20156	12" Intake Nozzle	1	--
65	20157	16" Intake Nozzle	--	1

ITEMS NOT SHOWN

		<u>TLR2910202BVG</u>	<u>TLBR3510252BVG</u>
70788	Replacement Hosing Liner (w/Hardware)	--	1
70858	Replacement Discharge Stack (w/Hardware)	1	1
39044	29hp Briggs & Stratton Engine	1	--
39043	35hp Briggs & Stratton Engine	--	1
31595	3/8-16 x 1-3/4 Hex Bolt (Engine Mount Bolt)	4	--
31097	3/8-16 x 1-1/4 Hex Bolt (Engine Mount Bolt)	--	12
31034	3/8 Flat Washer	--	24
31008	3/8 Lock Washer	4	12
31009	3/8-16 Nut	4	12
31810	Brass Fuel Tank Fitting 3/8 IPT to 1/4 Farrell	1	--
31828	Brass Fuel Tank Fitting 1/4 IPT to 1/4 Farrell	--	1
31753	1/4 Copper Fuel Line - 15" Length	1	1
31755	1/4 Rubber Fuel Line - 10" Length	1	1
34041	1/2" Hose Clamp	2	2
39190	Valve, Oil Drain	--	1
61215	Lock-on Hose 1/2	--	1
61233	Hydraulic Adapter 14MM	--	1
61234	Seal 14MM	--	1
39101	Battery Box (Plastic)	--	1
39020	Battery	1	--
39021	Battery	--	1
31642	Battery Cable 32SS	1	1
31643	Battery Cable 16SS	1	--
31826	Battery Cable 48SS	--	1
31836	Terminal Cover - Red	1	--
31837	Terminal Cover - Black	1	--
31453	Pusher Bolts	--	3
37172	Belt Guards Bearing Pulley	--	1
37173	Belt Guards Engine Pulley	--	1
37174	Belt Guards Right Bearing Box	--	1
37175	Belt Guards Left Bearing Box	--	1
36344	Belts 450-5	--	1
36347	Sheave, Pulley 6.90	--	1
36340	Bushing 1.438	--	1
36346	Sheave, Pulley 4.75	--	1
36233	Bushing 1.438	--	1
36163	Bearing 1.438	--	2
36345	Shaft, Impeller	--	1
31458	Collar, Split Single 1.438	--	2

Power Unit
Models
TLR2510201KH/
TLR3510251W

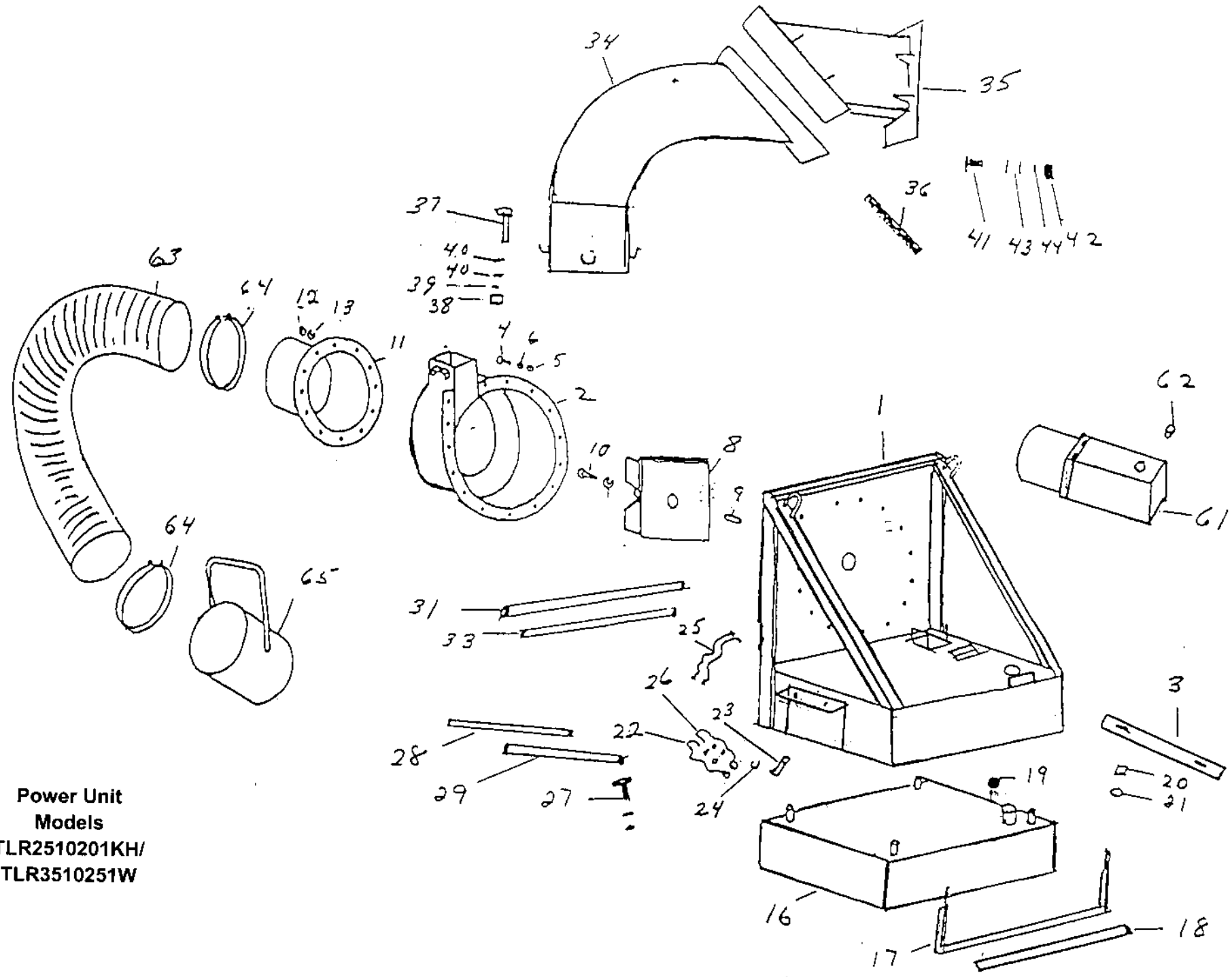

LEAF BOX AND FRAME SECTION

<u>REF. NO.</u>	<u>PART NO.</u>	<u>DESCRIPTION</u>	<u>TLR2910202BVG</u>	<u>TLBR3510252BVG</u>
85	27377	Trailer Frame	1	--
85	27378	Trailer Frame	--	1
86	33129	Axle and Spring Assembly	2	2
87	33125	Tire & Rim Assembly 8-14.5LT	4	4
88	33130	Rim Lock	20	20
89	33131	Lug Nut	20	20
90	27379	Leaf Box - 10-Cubic Yard	1	1
92	27191	Hoist Box Brackets	2	2
93	61112	Hoist Assembly - Complete	1	1
94	61052	Hydraulic Hose - 1/2 x 123	1	1
94a	61054	Hydraulic Hose - 1/2 x 143	1	1
95	31499	Running Light Assembly (cat's eye) - Red	7	7
95a	31501	Replacement Lens - Red	7	7
96	31500	Running Light Assembly (cat's eye) - Amber	4	4
96a	31502	Replacement Lens - Amber	4	4
97	33132	Dust Cap	4	4
98	33133	Bearing Seal	8	8
99	33134	Bearing	8	8
100	27192	Hoist Trailer Bracket	2	2
101	31503	Hoist Pin	1	1
102	31625	5/8-11 Handle Nut	2	2
102a	31489	5/8 Flat Washer	2	2
103	31504	Door Lock Pivot T-Bolt	2	2
104	27195	Door Lock Side Piece	4	4
105	31335	1/2-13 x 4 Hex Bolt	2	2
105	31021	1/2-13 x 4-1/2 Hex Bolt	4	4
105a	31406	1/2-13 Lock Nut	6	6
106	27380	Back Door	1	1
107	23160	Back Door Rod	1	1
108	31506	Door Gasket	1	1
115	31639	Tail Light Assembly with Mounting Ring	2	2
115a	31562	#12 x 3/4 Self Tap Screw (Taillight Grounding Screw)	2	2
116	27200	Door Latch Holder	2	2

ITEMS NOT SHOWN

31842	Wiring Harness - Trailer (Brakes, License, Taillights)	1	1
31845	Wiring Harness - Top Screen (Running Lights)	1	1
31751	License Light Assembly	1	1
31752	License Plate Mounting Bracket	1	1
31030	1/4-20 Hex Nut (License Light/Bracket Mounting)	4	4
31013	1/4 Lock Washer	2	2
31757	Bolt-On Wiring Harness Clip	15	15
31013	1/4 Lock Washer	15	15
31030	1/4-20 Hex Nut	15	15
31849	Plastic Cable Tie 28in	2	2

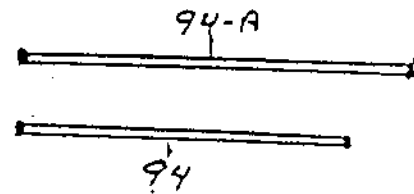
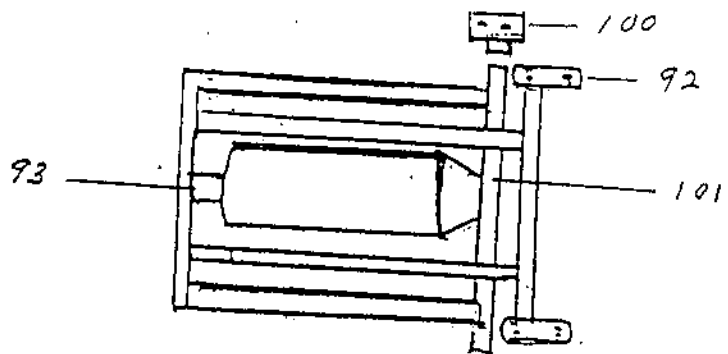
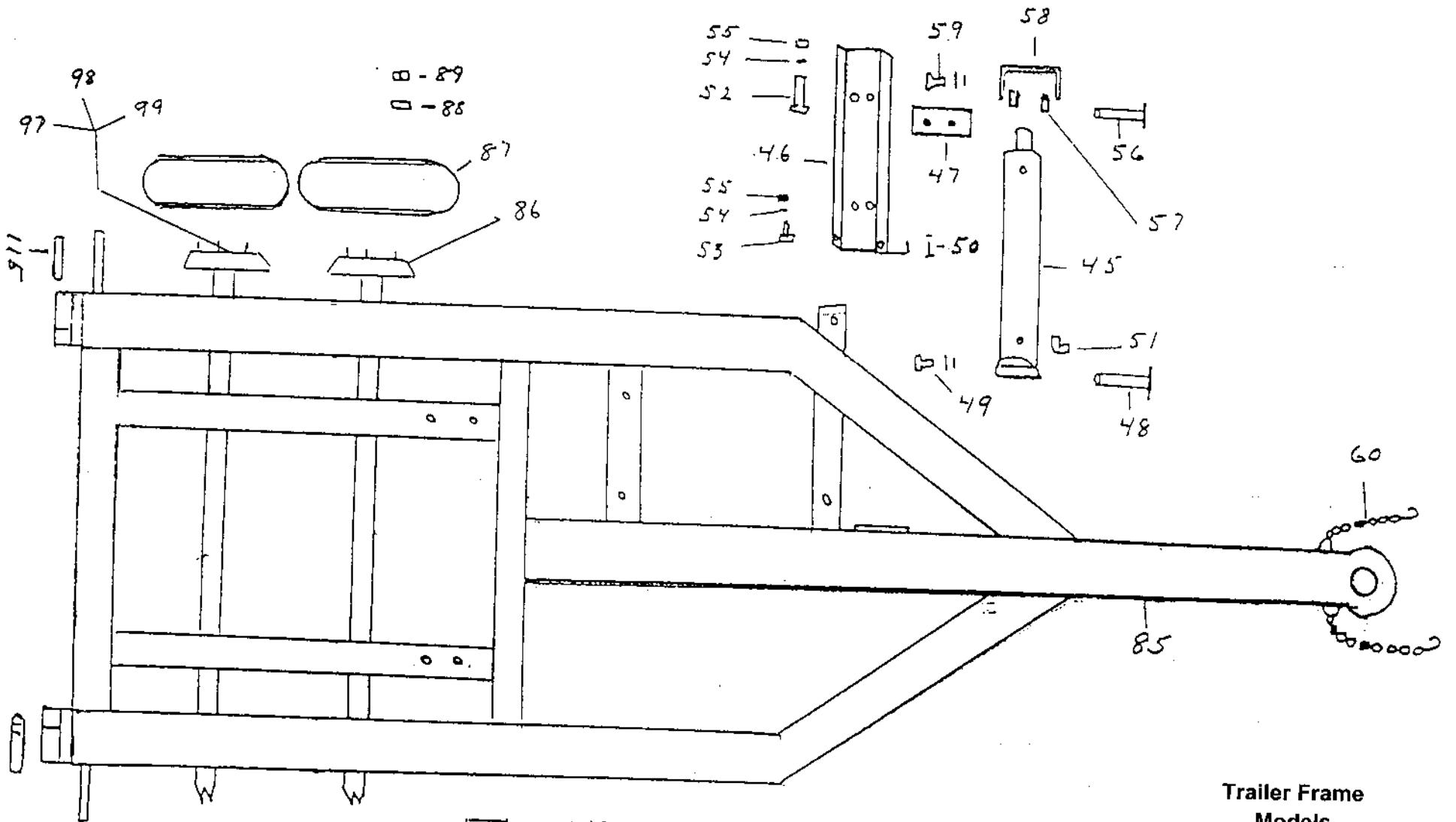

Trailer Frame
Models
 TLR2510201KH/
 TLR3510251W

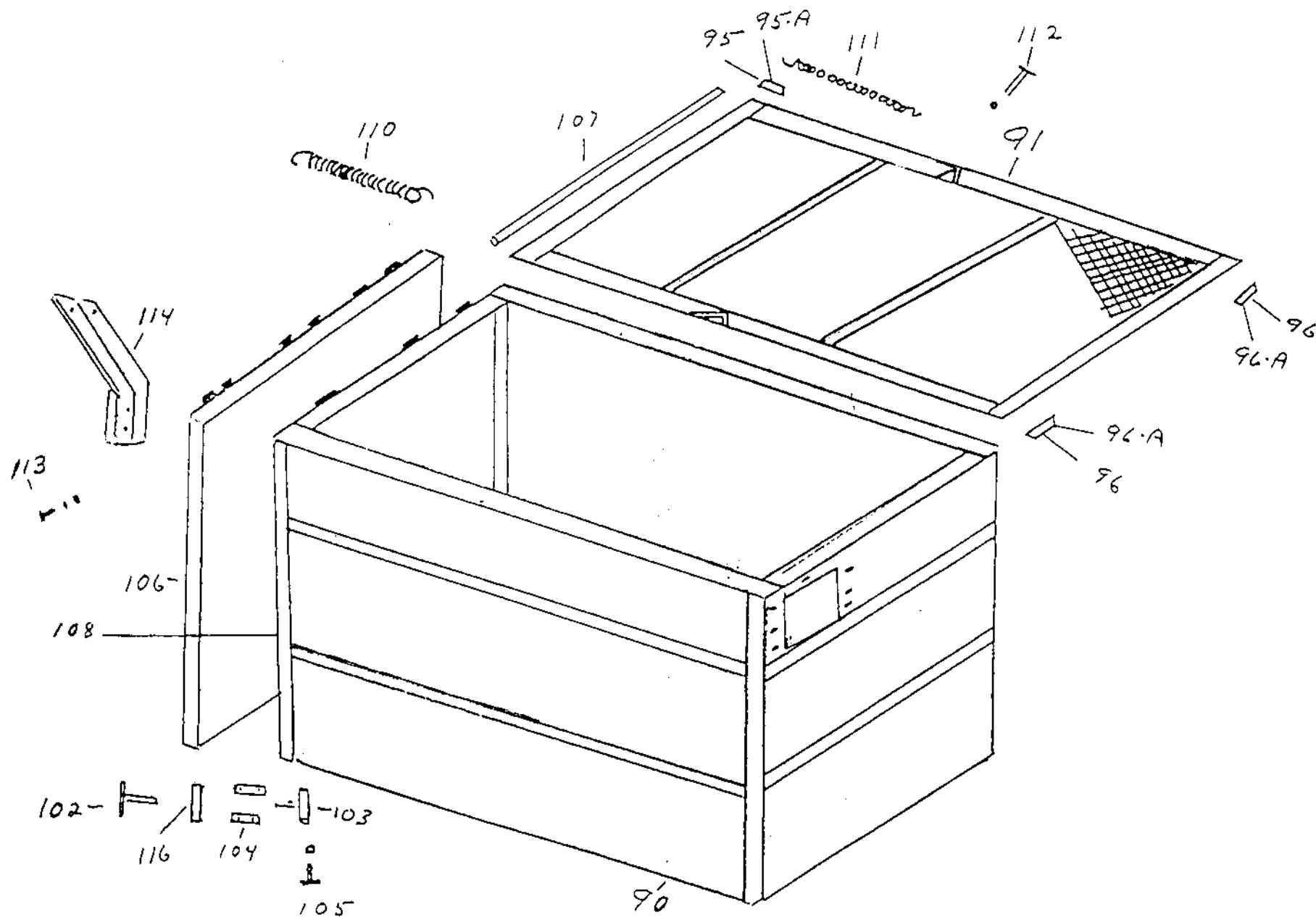

Leaf Box
 Models
 TLR2510201KH/
 TLR3510251W

HOSE SUPPORT BOOM

<u>REF. NO.</u>	<u>PART NO.</u>	<u>DESCRIPTION</u>	<u>TLR2910202BVG</u>	<u>TLBR3510252BVG</u>
1	40107	Boom Vertical Member	1	1
2	40106	Boom Horizontal Member	1	1
3	40108	Threaded Spring Guide	1	1
4	31110	3/4 Nut	3	3
5	31023	3/4 Flat Washer	2	2
6	31332	Boom Coil Spring	1	1
7	31025	1/2 x 3 Hex Bolt	1	1
8	31406	1/2 Lock Nut	2	2
9	31025	1/2 x 3 Hex Bolt	1	1
10	31140	Boom Chain	1	1
11	40110	Hose Support Band 12in	1	--
11	40111	Hose Support Band 16in	--	1
12	31141	5/16 x 3-1/2 Hex Bolt	1	1
13	31004	5/16 Hex Nut	2	2

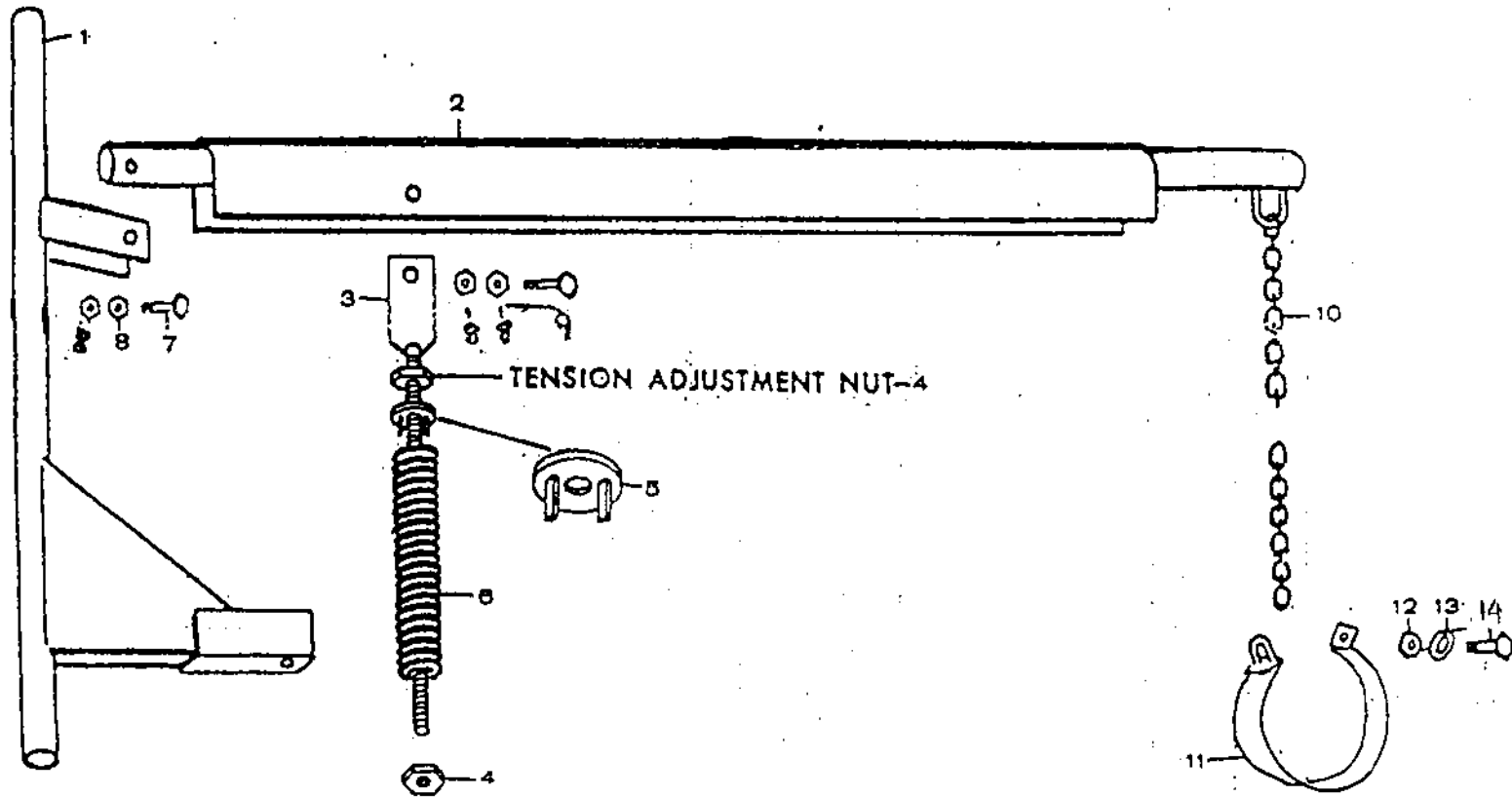

Hose Boom
 Models
 TLR2510201KH/
 TLR3510251W