

---

# ***THE GIANT-VAC TAILGATE TRUCK LOADER***

**Model TLG101651KH**

---

## **OPERATOR'S MANUAL**

---

### ***Congratulations!***

You have just purchased one of the finest pieces of outdoor power equipment on the market today. If properly cared for, your Giant-Vac Tailgate Truck Loader will provide years of dependable service. Please read and follow this instruction manual carefully in order to get the most out of your new equipment.

As you unpack your Truck Loader, you will find the following parts in **two** containers:

1 box containing:

- 1 Tailgate Truck Loader power unit
- 1 Package containing operating manuals and warranty registration

1 box containing:

- 1 Intake hose assembly (flange, hose, nozzle, 2 clamps)
- 1 Intake hose support boom assembly (2-piece boom, hose support band, chain)
- 1 Discharge elbow
- 1 Set of tailgate mounting components (2 upper arms, 2 lower arms)
- 1 Package of various assembly components and hardware

Your Giant-Vac Tailgate Truck Loader requires very little assembly. Simply follow the instructions contained within this manual to begin enjoying the benefits of your new unit.

Each Giant-Vac product leaves our factory in excellent condition; occasionally, however, some damage may occur during shipment. If any such damage is found upon initial inspection, *immediately* notify the transport carrier who delivered your machine, as they are solely responsible for such damage, as well as any subsequent adjustments necessary.

---

### **CALIFORNIA PROPOSITION 65 WARNING**

**Gasoline and Diesel engine exhaust and some of its constituents are known to the State of California to cause cancer, birth defects and other reproductive harm.**

**As an owner of off-road gasoline or diesel engine equipment and/or as an employer, you also may have an obligation under the California Occupational Safety and Health Act or under Proposition 65 to warn persons exposed to gas and diesel engine exhaust and/or other Proposition 65 chemicals in and around your workplace. See California Health and Safety Code section 25249.5, Title 22 of the California Code of Regulations at Section 1200 *et seq.*, and Title 8 of the California Code of Regulations Section 5194.**

---

---

# 1

## SAFETY RULES REGARDING OUTDOOR POWER EQUIPMENT

---

**IMPORTANT! READ THE FOLLOWING SAFETY RULES CAREFULLY BEFORE ASSEMBLING OR OPERATING UNIT:**

- Regard your Giant-Vac as a piece of power equipment and teach this regard to all who will operate this unit. Never allow children or young teenagers to operate the unit.
- Always wear appropriate safety equipment when operating this unit. Proper eye, ear, and breathing protection are a must.
- Be sure you know how to stop both the unit and the engine at a **MOMENT'S NOTICE**. Refer to the operation section of this manual, as well as the engine manual.
- Do not operate with any guards or component parts removed from unit.
- Unless there is very good artificial light, use only during daylight.
- Fill gasoline driven machines outdoors. Avoid spilling gasoline and **DO NOT** fill the engine while it is running or while you are smoking.
- While in operation, keep all parts of body away from intake and exhaust sections. Never insert any body part or other foreign object in any opening while the machine is running.
- When operating unit, keep people and pets a safe distance away. Instruct children to keep away from the area of operation at all times.
- Do not use on steep inclines (over 30 degrees), as unit can roll over.
- Before making any adjustments or repairs, stop engine and remove spark plug wire.

---

**FAILURE TO FOLLOW THESE RULES CAN RESULT IN CHRONIC HEALTH PROBLEMS, SERIOUS INJURY, OR EVEN DEATH.**

---

---

# 2

## UNIT ASSEMBLY & MOUNTING

---

### UNIT ASSEMBLY

**Note: Please refer to parts list for correct part identification and placement**

#### **FRONT PUSHER PLATE ASSEMBLY:**

- Thread Pusher rod (Parts list ref. #18) out through lower threaded hole in rear channel of power unit frame (#1), allowing approximately 3" to protrude from rear of unit.
- Slide Pusher rod handle (#19) through hole in top of pusher rod, securing with 3/8" lock nut (#19a).
- Slip one 1/2" flat washer (#22) onto small tapped end of pusher rod, followed by front pusher plate (#24), small hole facing unit, guiding end of pusher rod through hole. Secure pusher plate with second 1/2" flat washer, 3/8" flat washer (#21), 3/8" lock washer (#23) and 3/8" x 3/4" hex bolt (#20). Repeat for other side. Refer to Picture (1).

#### **REAR HOLDER ARM ASSEMBLY:**

- Insert one 5/8" x 4" hex bolt (#26), fitted with one 5/8" flat washer (#28) through bushing side of hole in rear holder arm. Threaded side of bolt should protrude from flat side of arm.
- Attach holder arm, flat side toward unit, to bracket in top rear of unit, securing with second 5/8" flat washer and 5/8" lock nut (#27). Note: leave arm loose enough to swivel up for easier mounting. Repeat for other side.

#### **DISCHARGE ELBOW ASSEMBLY:**

- Position elbow retaining ring (#16a) over the exhaust elbow and stack (#16). Secure elbow to the machine with (4) 5/16 x 1" bolts (#16b), (4) 5/16" pivot spacers (#16c), and (4) 5/16" lock nuts (#16d) tighten securely grease upper and lower rings so elbow can swivel. Next secure stack extension (#16e) over end of elbow with the stack extension retainer (#16g) using the 3/8" wing bolt (#16f), 3/8" lock nut washer (#16h) and 3/8" wing nut (#16i), then adjust to fit leaf box. Refer to Picture (2).

#### **INTAKE HOSE ASSEMBLY:**

- Install intake flange (#5) to power unit with 5/16" x 3/4" bolts (#6) and lock washers (#6a). Flip up intake flange safety cover (#5a; this should already be installed onto the intake flange by the factory) and install quick-attach hose adapter (#5b) to intake flange. **Important: Be sure to lock hose adapter into intake flange by pushing adapter into flange as far as it will go, then twisting into locking slots.** Secure adapter by installing 5/16" fender washer and 5/16" plastic knob nut onto each adapter stud. Install 5/16" locknut onto each stud, tightening snugly against knob nut to prevent loosening and/or loss of knob nut, and subsequent disconnection of hose adapter. Refer to Picture (3).
  - Attach intake hose (#8) to hose adapter using one hose clamp (#7). Assemble hose support band (#9) around intake hose approximately 3-1/2 feet from free end of hose using 5/16" hex head bolt (#10) with two nuts (#10a) locked together. Now attach intake nozzle (#11) to loose end of intake hose using the remaining hose clamp.
-



Picture (1)



Picture (2)



Picture (3)

## 2 UNIT ASSEMBLY & MOUNTING (cont.)

---

### **HOSE SUPPORT BOOM ASSEMBLY:**

- Attach upper boom member (#14) to lower boom pipe (#13) so that upper boom extends out at an upward angle. Secure with two ½ x 1-1/4" hex bolts, lock washers and nuts (#15).
- Lower bottom of lower boom pipe through hole in support bracket on side of discharge elbow and onto boom pivot rod, located on top of unit housing.
- Slip on end of support chain (#12) into hole in end of upper boom member. Slip other end through eye of hose support band and hook to link in center of chain. After mounting, adjust chain so that nozzle rests approximately 12" from the ground.

### **A NOTE ABOUT DEBRIS BOXES:**

- The Giant-Vac Tailgate Truck Loader is designed to be used in conjunction with a leaf receiver box. Debris should not be discharged into an open bed, as injury and/or damage may result. A simple truck-bed-fitted debris box may be constructed with plywood sides and front (3/4" exterior is recommended), reinforced with angle iron corners, a hinged and latched plywood dump door with a rubber-aproned cut-out for insertion of the discharge chute, and a mesh screen top to allow for adequate ventilation. Be sure that the height of the box extends approximately 8-12" higher than the top of the discharge chute to prevent excessive blow-by.

## **UNIT MOUNTING**

**Caution:** Before mounting the Giant-Vac Tailgate Truck Loader to the tailgate of the transport vehicle, it is recommended that the tailgate be reinforced with ¾" plywood to prevent damage to the tailgate.

**Caution:** Individuals should not attempt mounting the Tailgate Truck Loader without assistance. Serious injury may result.

**Caution:** Be sure truck tailgate is securely locked before mounting truck loader. Failure to do so may result in serious injury or damage.

- Lifting the unit so that the holder arms clear the top of the tailgate, butt the rear of the unit against the tailgate and lower into place, hooking the rear holder arms onto the inside of the tailgate. Tighten the rear holder arm bolts, making sure the rear holder arms are facing downward.
- Tighten the pusher rods until the front pusher plates clamp the unit securely to the tailgate.

---

# 3 UNIT OPERATION AND TRANSPORT

---

## **STARTING THE ENGINE**

*IMPORTANT NOTE: The procedures outlined within this section are general guidelines, and are in no way meant to replace or supersede engine manufacturer's operating instructions. In order to obtain optimum performance from your engine, refer to your engine manual.*

### **BEFORE STARTING ENGINE:**

- Be sure that the unit is completely assembled, all fasteners are tightened securely, and all safety guards and components are in place.
- Be sure to check engine's **oil** and **gasoline\***. (See engine manual for recommended oil and gasoline specifications.) **Never** check the engine while it is running or while you are smoking. Check only when engine is cold.  
**\* All machines are shipped without oil or gasoline unless otherwise noted.**
- Be sure that fuel valve on engine is set to open position (if applicable).

### **TO START ENGINE:**

- Set throttle control to "ON" position. If engine is cold, set choke (if so equipped). If your engine has a fuel prime button, depress it firmly three times.
- Grasp recoil handle and pull briskly. You may have to pull several times before engine starts. (If engine fails to start within a reasonable amount of time, discontinue and check engine manual for further instructions.)
- After engine starts, move throttle control down to approximately half, and turn off choke.

### **TO SHUT ENGINE DOWN:**

- Allow engine to idle for 2-3 minutes before shutting down.
- Set throttle control to 'off' position.
- If engine is not to be started for a prolonged period, turn fuel valve to closed position.

*IMPORTANT NOTE: If you experience problems with your engine that cannot be satisfactorily resolved by following the instructions contained within the engine manual, contact your local engine dealer, or call the toll-free service number listed in the repair section of the engine manual. All engine service, warranty or otherwise, is required to be performed by a manufacturer-authorized service center. Giant-Vac, Inc. is neither authorized nor responsible for any type of warranty engine service, nor is it equipped to perform any such service.*

---

# 3 UNIT OPERATION AND TRANSPORT (cont.)

---

## **OPERATING THE UNIT:**

***DANGER! Never insert any part of the body or foreign object in any opening while machine is running.***

### ***GENERAL OPERATING GUIDELINES:***

- Check chain adjustment before use. With engine throttled up to full operating speed, you should be able to push the nozzle to the ground and pull it back up using three fingers of one hand. If not, adjust chain length accordingly by slipping the S-hook into an appropriate mid-link.
- If leaves are dry, run engine at approximately half throttle. This will help reduce debris blow-by through the screen. If leaves are wet, run engine at full throttle.
- For dry leaves, a short back and forth flicking motion of the nozzle just above the pile should be sufficient. For wet leaves, dig into the pile with a gulping motion, and then move the nozzle away to allow leaves to flush through.
- Avoid sand, gravel or stones, as debris of this nature is very abrasive and can damage the impeller and housing.
- Make sure the driver of the vehicle has operator in full view at all times. Operator should stand to the side of the vehicle when operating truck loader, never behind.

## **TRANSPORTING THE UNIT:**

***Caution: When transporting Truck Loader, do not exceed 30 mph. High-speed driving and poor road conditions can cause damage to the truck loader and towing vehicle.***

- Remove the boom chain and swivel hose support boom to side of debris box and secure with rope or hardware. Fasten hose and nozzle to unit frame using rubber tie down (#29).

---

# 4

## MAINTENANCE AND STORAGE

---

- Follow **implicitly** the engine manufacturer's recommendations for maintenance.
- Never make any adjustments to the unit until the engine is **off** and the spark plug wire is disconnected.
- If carburetor adjustment is necessary, stand to one side and **keep feet and hands** in the clear while making adjustments.
- Keep engine free of accumulations of grass, leaves or excessive grease. An accumulation of these combustible materials may result in a fire.
- Store gasoline in a **safe and approved** container in a cool, dry place.
- Keep the unit and any fuel containers in locked storage to prevent children from playing and/or tampering with them.
- Do not store gasoline powered equipment or fuel containers in a basement or any closed area where heating or heat appliances or open pilot lights are present, unless the fuel is completely drained from the power equipment and the fuel containers.



---

# **GIANT-VAC WARRANTY**

---

**GIANT-VAC, INC.**, here in after called Giant-Vac, warrants each new Giant-Vac to the original retail purchaser of the new Giant-Vac equipment to be free from manufacturing defects in normal service for a period of 1 year, unless it is used for rental purposes, which limits the warranty to 30 days. This warranty does not apply to engines, tires or other parts that are purchased and warranted by their manufacturer. Items such as bags, grass catchers, hose and blades are not warranted, as these are considered expendable items. This warranty does not include equipment failures due to normal wear.

Any obligation under this warranty is expressly limited to the replacement or repair, at an authorized servicing Giant-Vac dealer, or at a point designated by us, of such parts as appear to us to have been defective. All defective parts have to be returned freight prepaid before credit will be issued.

We shall not be liable for transportation charges in connection with the replacement or repair of defective parts.

This warranty does not apply to a Giant-Vac upon which repairs or alterations have been made by others except with our prior written approval.

We shall not be liable for consequential damages or contingent liabilities for the fitness of any Giant-Vac for any particular purpose.

We make no other express, implied or statutory warranty, nor is anyone authorized to make any in our behalf.

---

**GIANT-VAC, INC.  
535 Macon Street  
McDonough, GA 30253  
PHONE: 866-792-8223**

---

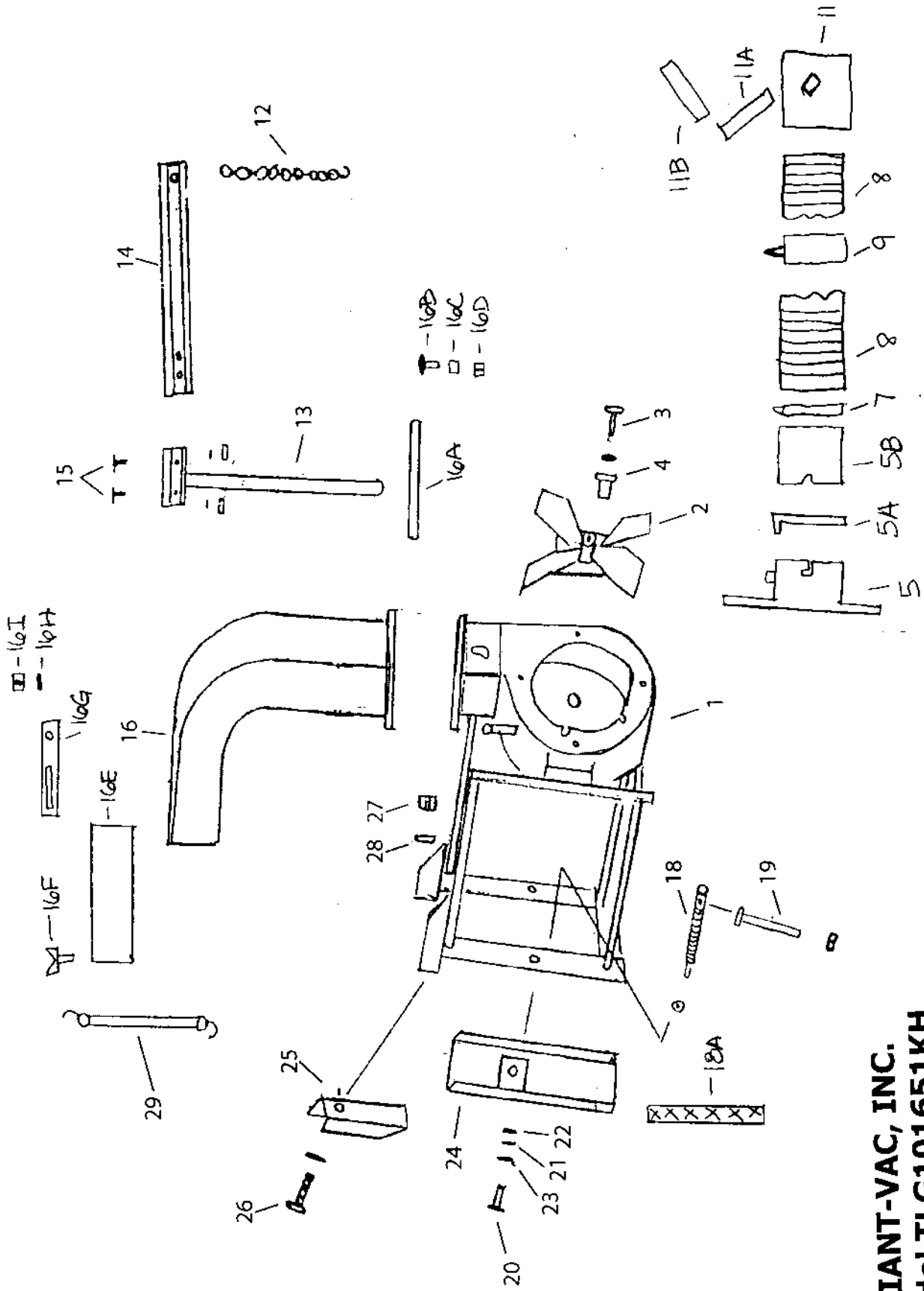

**GIANT-VAC, INC.**  
**Model TLG101651KH**  
**R0207.1**

<b>REF. NO.</b>	<b>PART NO.</b>	<b>DESCRIPTION</b>	<b>TLG101651</b>
1	10116	Motor Base & Housing	1
2	21608	Impeller (Complete w/Hub & Hardware - Includes Ref. 3 & 4)	1
3	31005	5/16-18 x 1-1/4 GR5 Hex Bolt	3
--	31003	5/16 Lock Washer	3
4	21560	Taper-Lok Hub 1in Diameter	1
--	21594	Taper-Lok Hub Cover	1
5	20200	Intake Flange	1
5a	20202	Intake Flange Safety Cover 8"	1
5b	20204	Quick-Release Hose Adapter 8"	1
--	31890	5/16 Fender Washers	2
--	31626	5/16 Knob Nuts	2
--	31004	5/16 Lock Nuts	2
--	31997	5/16 Star Washer	2
6	31660	5/16 x 3/4 Thread Bolt	4
6a	31003	5/16 Lock Washer	4
7	34015	8in Hose Clamp	2
8	34006	Intake Hose 8.00 x 10ft	1
9	40120	Hose Support Band	1
10	31623	5/16 x 2-1/2 Hex Bolt	1
10a	31004	5/16-16 Hex Nut	2
11	20140	Intake Nozzle 8in	1
11a	20141	Intake Nozzle Adjustable Handle	1
11b	31590	Intake Nozzle Handle Grip	1
12	31140	Boom Chain	1
13	40121	Lower Boom Support	1
14	40122	Upper Boom Support	1
15	31093	1/2-13 x 1 Hex Bolt	2
--	31078	1/2 Lock Washer	2
--	31022	1/2-13 Nut	2
16	24597	Exhaust Elbow & Stack	1
16a	24600	Elbow Retaining Ring	1
16b	31032	5/16-18 x 1" Hex Bolt	4
16c	24601	5/16 Pivot Spacers	4
16d	31004	5/16 Lock Nuts	4
--	31003	5/16 Lock Washer	4
--	31613	Grease Fitting .250	2
16e	24598	Stack Extension	1
16f	31026	3/8 Wing Bolt	1
16g	24599	Stack Extension Retainer	1
16h	31115	3/8 Lock Washer	1
16i	31009	3/8 Wing Nut	1
18	31494	Pusher Rod 1 x 7	2
18a	31889	Rubber Gasket	1
19	31495	3/8-16 x 5 Hex Bolt (Pusher Rod Handle)	2
19a	31355	3/8-16 Lock Nut	2
20	31492	3/8 x 3/4 Hex Bolt	2
21	30134	3/8 Flat Washer	2
22	31043	1/2 Flat Washer	4
23	31008	3/8 Lock Washer	2
24	23158	Front Pusher Plate	2
25	23159	Rear Holder Arm	2
26	31907	5/8 x 4 Hex Bolt	2
27	31490	5/8 Lock Nut	2
28	31489	5/8 Flat Washer	2
29	31358	Rubber Tie Down	1

### **ITEMS NOT SHOWN**

39126	10hp Kohler Command Pro Engine	1
39122	Muffler Deflector	1
39123	Clamp for Muffler Deflector	1
31112	3/8-16 x 1-1/2 Hex Bolt (Engine Bolt)	4
31987	3/8-16 Small Serrated Flange Nut	2
32132	3/8-16 Large Serrated Flange Nut	2
31813	1/2 Housing/Engine Spacer	4
31796	5/16-24 x 1-1/4 Hex Bolt (Vibration Suppression Bolt)	4
31003	5/16 Lock Washer	4
31027	5/16 Flat Washer	4
31034	3/8 Flat Washer	6
31794	Impeller Bolt .375-24 x 2	1
79300	Decal, Danger Safety	1
79301	Decal, Warning Safety	1
79302	Decal, Notice	1
79174	Decal, GV Logo, .9in White on Black	1